



3D Probe Analogue

IP67 MADE IN GERMANY PATENT

Our patented analogue 3D probe reduces setup times and downtimes by quickly and accurately probing reference edges, setting zero points and measuring workpieces.

Technical drawing

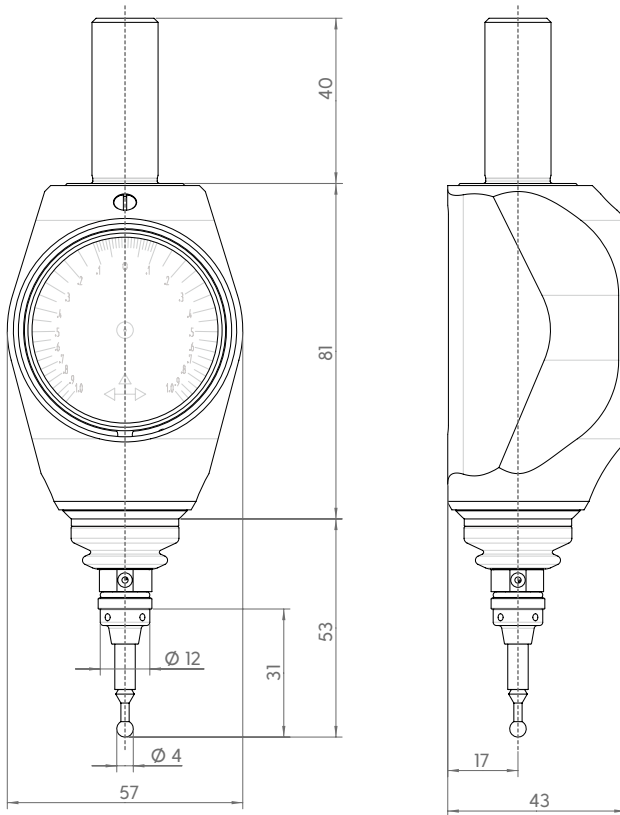

Applications examples



Benefits

- High precision
- Simple gauge calibration
- Fine scaling of display range for accurate readings
- Scaling for radial and axial probing
- Comfortable and simple concentricity adjustment
- Large working area in all directions
- Shock proof and water proof according to IP67
- Compact metal housing and long probe arm
- Screw-on probe tip
- Robust construction
- Stylus with defined breaking point

Technical Data

- Shaft diameter: 16 mm
- Measuring accuracy: 0.01 mm
- Dimensions: 174 x 57 x 43 mm
- Available length of probe arm: 40 mm
- Weight: 397 g

Item number

- Haff & Schneider Art. No. 106000-2MM

Accessories

- Standard probe tip: Art. No. 107323
- Probe tip long: Art. No. 107323-long
- Bellow: Art. No. 105451
- Sight glass: Art. No. 34-03798